



VS 5 ECO

(all dimensions in mm)

Permeable paving system with shift protection and drainage joint for road surfaces

Shape and dimensions, normal stone

Grid size	225 mm x 225 mm
Nominal size	201 mm (± 2 mm)
Outside dimension	224 mm (± 2 mm) incl. spacing aids
Nominal thickness	80 mm or 100 mm (± 3 mm)
Stone thickness, overall	88 mm or 108 mm (± 3 mm) (including profiling on underside)
Weight	approx. 9 kg/stone (80 mm) approx. 11 kg/stone (100 mm)
Opening proportion	approx. 10 % drainage openings
Joint width	visible: 24 mm
Chamfer	2 mm vertical, 3 mm horizontal
Spacing aids	11.5 mm interlocking spacing aids for shift protection
Top side	according to plan, planar
Stone side	according to plan, planar with interlocking spacing aids
Underside	profiled, 8 mm

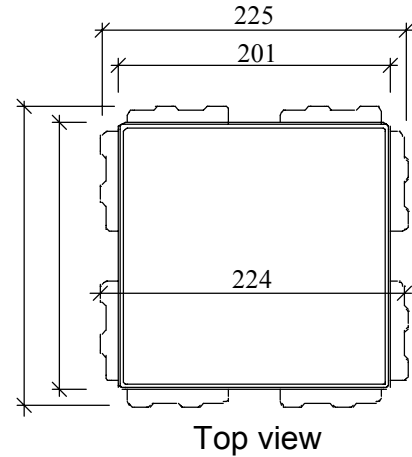

Top view

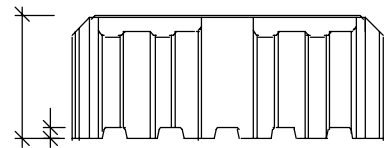

Side view

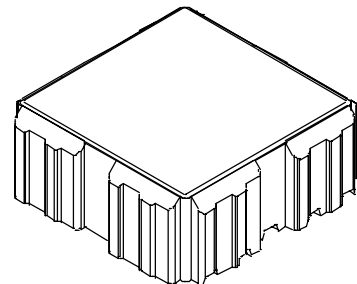

Top view

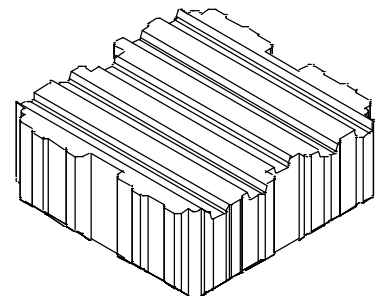

Stone underside

Info sheet technical data

Product
VS 5 ECO

Product group
Permeable Pavements

Page
1 of 8

Last revision
September 2007



VS 5 ECO

(all dimensions in mm)

Permeable paving system with shift protection and drainage joint for road surfaces

Shape and dimensions, supplementary half-stone product

Grid size	112.5 mm x 225 mm
Nominal size	201mm x 88.5 mm (±2 mm)
Outside dimension	224 mm x 111.5 mm (±2 mm) incl. spacing aids
Nominal thickness	80 mm / 100 mm (±3mm)
Stone thickness, overall	88 mm / 108 mm (±3mm) (including profiling on underside)
Weight	approx. 4 kg/stone (80 mm) approx. 5 kg/stone (100 mm)
Opening proportion	approx. 10 % drainage openings
Joint width	visible: 24 mm
Chamfer	2 mm vertical, 3 mm horizontal
Spacing aids	11.5 mm interlocking spacer supports for shift protection
Top side	according to plan, even
Stone side	according to plan, even with interlocking protection support
Underside	profiled, 8 mm
Special note	The half stone VS 5 ECO is only available as an extension stone for the product VS 5 ECO 225 x 225.

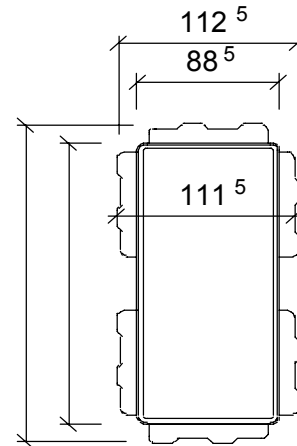

Top view

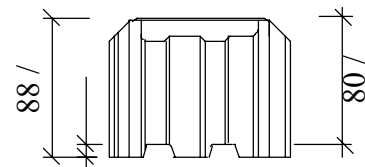

Side view

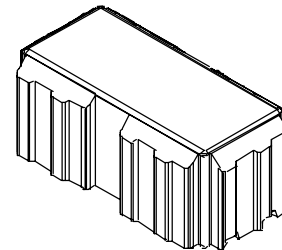

Top view

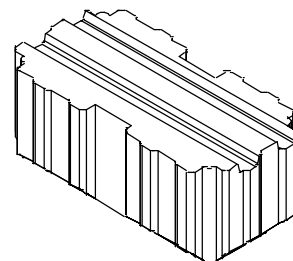

Stone underside

Product	VS 5 ECO	Page	2 of 8
Product group	Permeable Pavements	Last revision	September 2007



VS 5 ECO

Permeable paving system with shift protection and drainage joint for road surfaces

Note on laying

Demand for laying

19.75 Stones/m²

mass per m² area

approx. 170 kg/m² (80 mm), approx. 220 kg/m² (100 mm),

Application

Permeable pavement for vehicle and/or pedestrian traffic in private, commercial, industrial yards or public areas.

Due to the high shift protection, VS 5 ECO is particularly suitable for road surfaces subjected to high horizontal stresses such as curves and the maneuvering, braking and acceleration of vehicles.

The best possible shift protection is achieved in running respectively half Bond patterns. The profiling on the underside should run in the main traffic direction.

Combination with VS 5 300/300

VS 5 ECO in grid size 225 mm is combinable via the interlocking spacers with VS 5 stones in raster size of 300 mm.

Due to this, the shift protection is maintained across both types of stone.

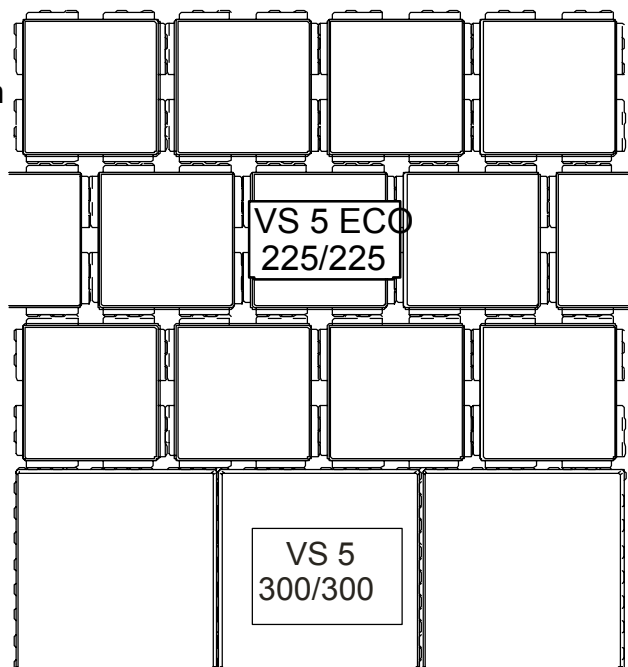

Product
VS 5 ECO

Product group
Permeable Pavements

Page
3 of 8

Last revision
September 2007



VS 5 ECO

Permeable paving system with shift protection and drainage joint for road surfaces

Shipping formations

VS 5 ECO can be laid manually or by machine.

Shipping formation without half-stones

Shipping formations are obtainable with or without half-stones.

For vehicle thoroughfares and for a better interlocking effect, half-bond laying is recommended.

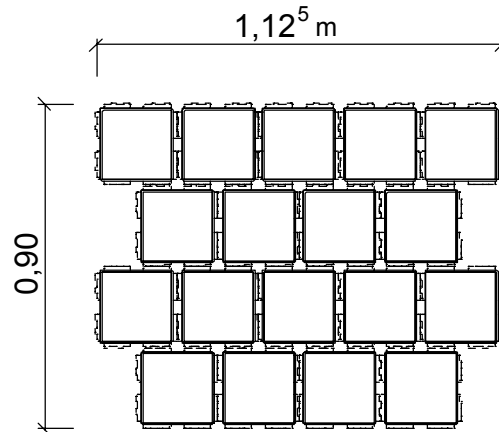

Shipping formation without half-stones

Shipping formation with half-stones

For the shipping formation with half-stones, the half-stones must be exchanged during laying in order to avoid continuous joints.

Exchanged half-stones must be laid in edge areas.

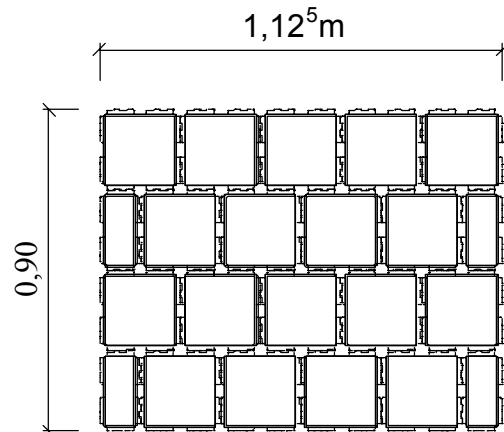

Shipping formation with half-stones

Machine laying in cross bond

In the case of machine laying in a cross bond for non-vehicle surfaces, braces with stone row displacement must be used. Missing stones must be subsequently inserted by hand.

Product
VS 5 ECO

Product group
Permeable Pavements

Page
4 of 8

Last revision
September 2007



VS 5 ECO

Permeable paving system with shift protection and drainage joint for road surfaces

References for design

Drainage capability

VS 5 ECO offers high drainage performance due to its high joint proportion of 10 %.
The prerequisite for this is the use of suitable joint and bedding material.

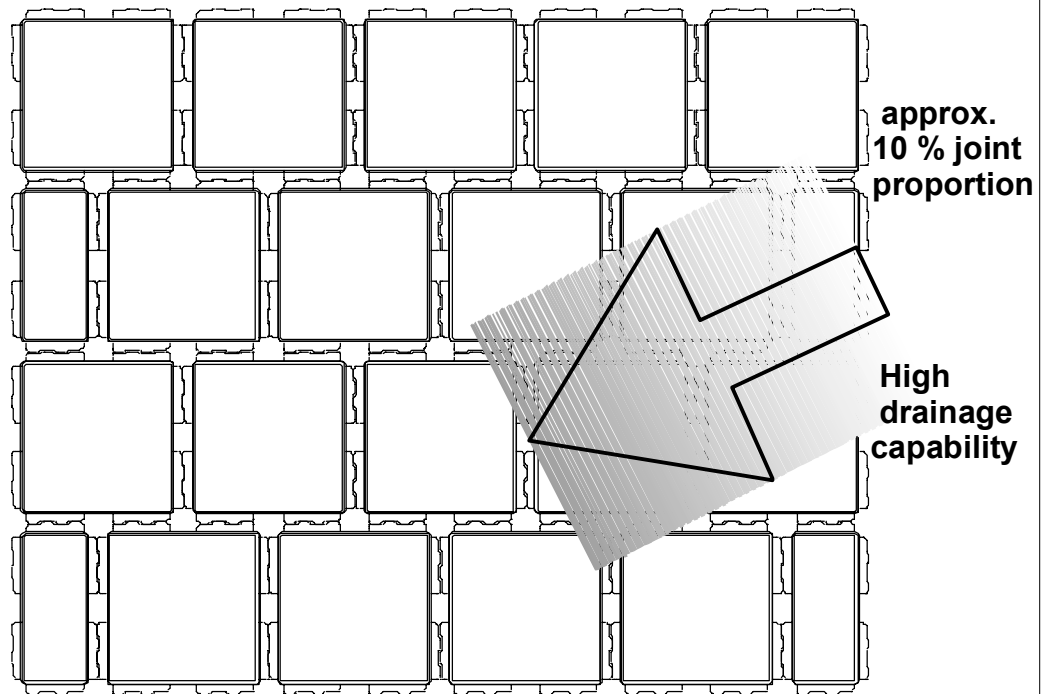

With the VS 5 ECO, the precipitation amounts of the reference rain of 270 l/(s x ha) = 3 inches/hour for the construction of water permeable road surfaces can also be completely drained, even in the long-term, if the correct aggregates are used for joints, bedding and base layer and the basic principles for regular execution of construction work are complied with.

Notes on the planning and execution of construction work on the following page.

VS 5 ECO is not intended to be used as a turf pavement.

Product
VS 5 ECO

Product group
Permeable Pavements

Page
5 of 8

Last revision
September 2007



VS 5 ECO

Permeable paving system with shift protection and drainage joint for road surfaces

Construction

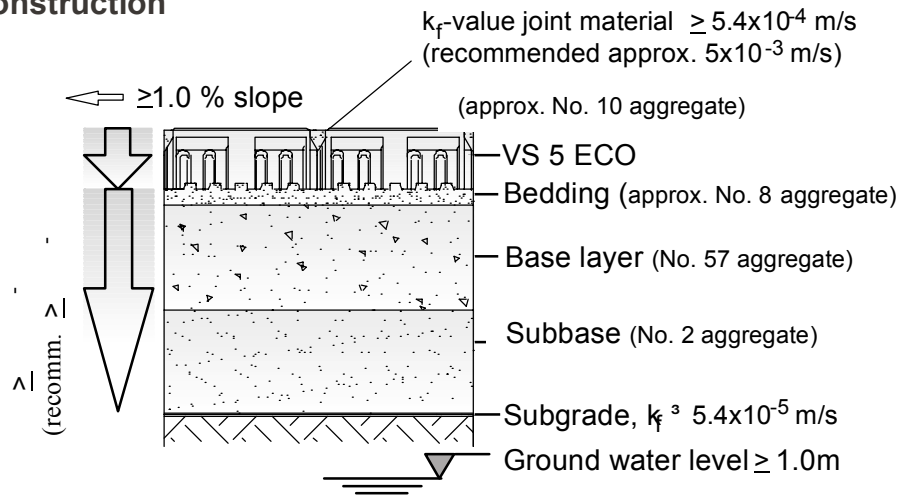

Construction of permeable pavements

Joint material

The water permeability k_f of the joint material must be at least 5.4×10^{-4} m/s. A 1/3mm broken aggregate with a k_f -value of approx 5×10^{-3} m/s is recommended. (Approximately No. 10 aggregate or similar).

Bedding material

The water permeability k_f of the bedding material must be $\geq 5.4 \times 10^{-5}$ m/s. A 1/5 mm or 1/3 mm broken aggregate with a k_f -value of approx. 5×10^{-4} m/s is recommended.

Base and sub base layer

The water permeability k_f of the base and anti-frost layer must be at least 5.4×10^{-5} m/s. A permeability value of 5.4×10^{-4} m/s is recommended, composed of 0/32 or 0/45 mm broken aggregate with a max. fines content of 5% mass (≤ 0.063 mm grain diameter) in the delivery condition. For the grain composition, the lower area of the sieve lines is to be aimed for. The deformation modulus E_{v2} must not exceed 120 MN/m^2 , with a ratio E_{v2}/E_{v1} of between 2.2 und 2.5. In the case of higher individual loads, bound water permeable base layers with filter fleece can also be used.

Subgrade and sub-soil

The sub-grade and the sub-soil must be prepared with a sufficient gradient and water permeability. The distance to the highest groundwater must be at least 1.0 m.

Product
VS 5 ECO

Product group
Permeable Pavements

Page
6 of 8

Last revision
September 2007



VS 5 ECO

Permeable paving system with shift protection and drainage joint for road surfaces

Parking lot with parking spaces of varying widths

Example of parking lot design

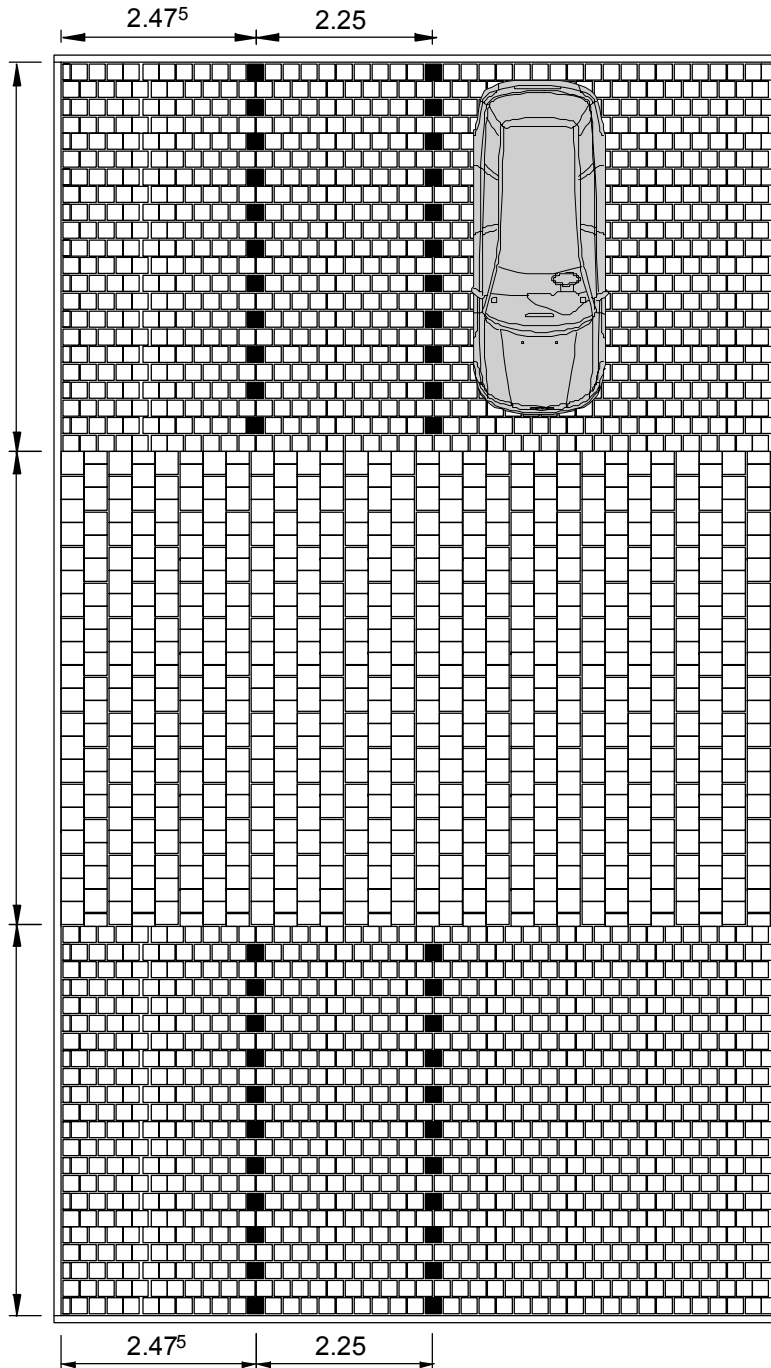

VS 5 ECO
225 x 225 mm

VS 5
300 x 300 mm

VS 5 ECO
225 x 225 mm

Info sheet technical

Product
VS 5 ECO

Product group
Permeable Pavements

Page
7 of 8

Last revision
September 2007

SF Concrete Technology Inc.
3338 Enniskillen Circle
Mississauga, Ontario L5M 2M8
Tel. 905 828 2868 Fax 905 279 9164
info@sconcrete.on.ca www.sconcrete.com



VS 5 ECO

Permeable paving system with shift protection and drainage joint for road surfaces

Product data sheet

VS 5 ECO 225/225/80		
	Normal stone	Half stone
Nominal sizes and tolerances		
- Length [mm]	201 ±2	201 ±2
- Bridth [mm]	201 ±2	88.5 ±2
- Thickness [mm]	80 ±2	80 ±2
Grid size [mm]	225	225 / 111.5
Size [mm]	201 / 201 / 80	201 / 88.5 / 80
Stone thickness overall [mm]	88 ±2	88 ±2
Joint ratio	approx. 10 %	
Chamfer	2 mm vertical, 3 mm horizontal	
Spacer	Projection size: min. 10 mm, max. 13 mm	
Conicity	according to plan, none, max. 1 mm	
Top side	according to plan, even	
Underside	profiled	
Lateral surfaces	according to plan, even with spacer	
Colors	in accordance with manufacturers specification	
surface treatment	in accordance with manufacturers specification	
Composition and manufacture	VS 5 Eco is made of a "no slump" concrete mix. Compressive strength is greater than 8000 psi, a water absorption maximum of 5% and will meet or exceed ASTM C-936 and freeze-thaw testing per Section 8 of ASTM C-67.	

Product	VS 5 ECO	Page	8 of 8
Product group	Permeable Pavements	Last revision	September 2007

